

NOTES:

1. WIRE MATERIAL: SPRING STEEL
2. WIRE DIAM.: 0.3mm
3. ASSOCIATED CAD FILE: GovernorSpring.STP
4. SHOWN IN RESTING POSITION
5. PHYSICAL SAMPLE AVAILABLE

REVISION HISTORY				
ZONE	REV	DESCRIPTION	DATE	APPROVED
	0	INITIAL RELEASE	12/22/2020	J. HAUPT

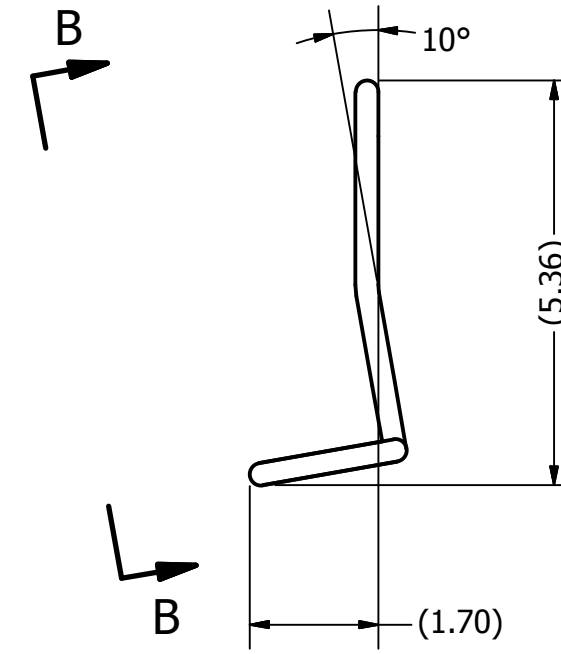
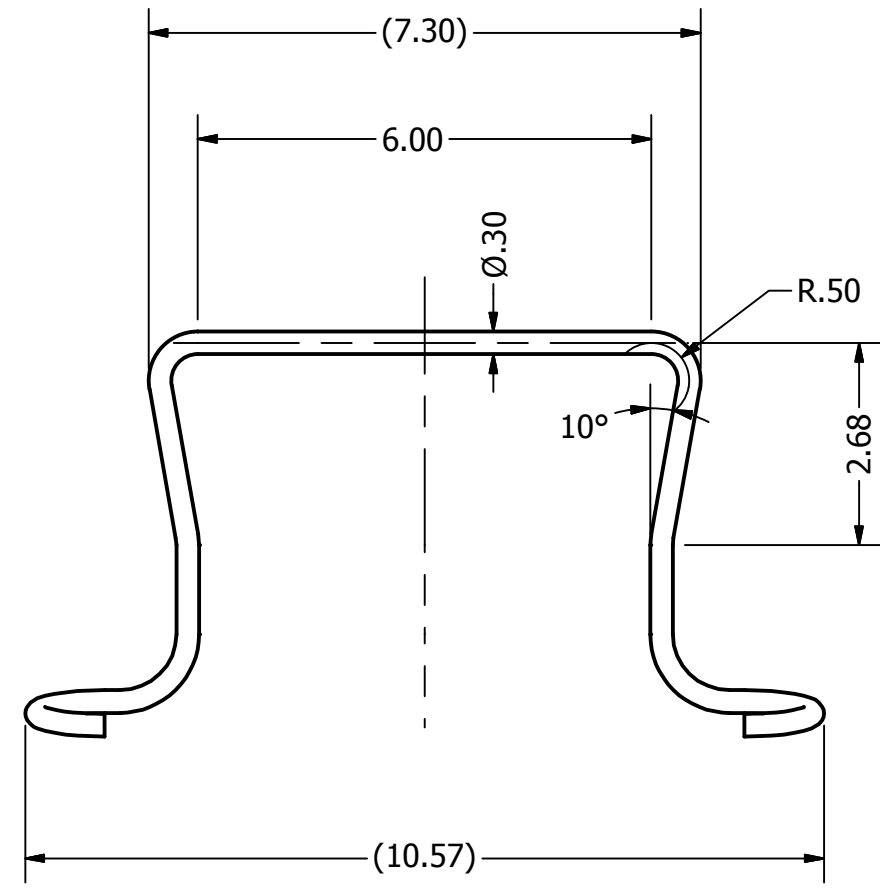

VIEW B-B

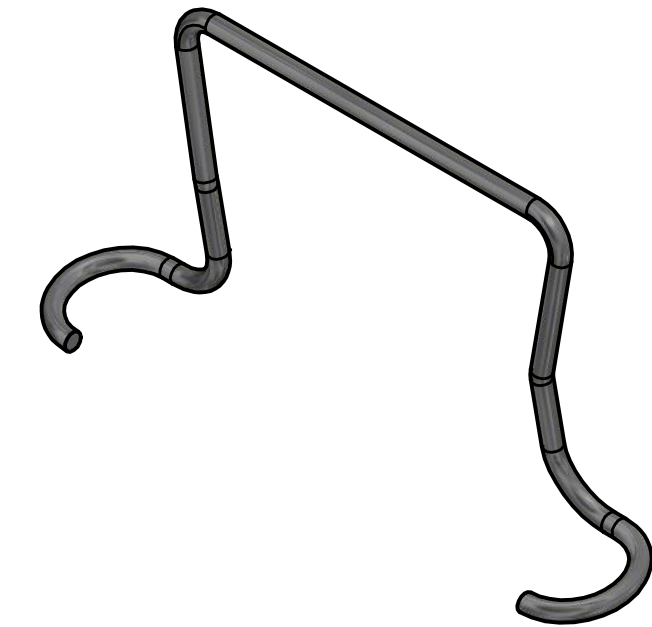
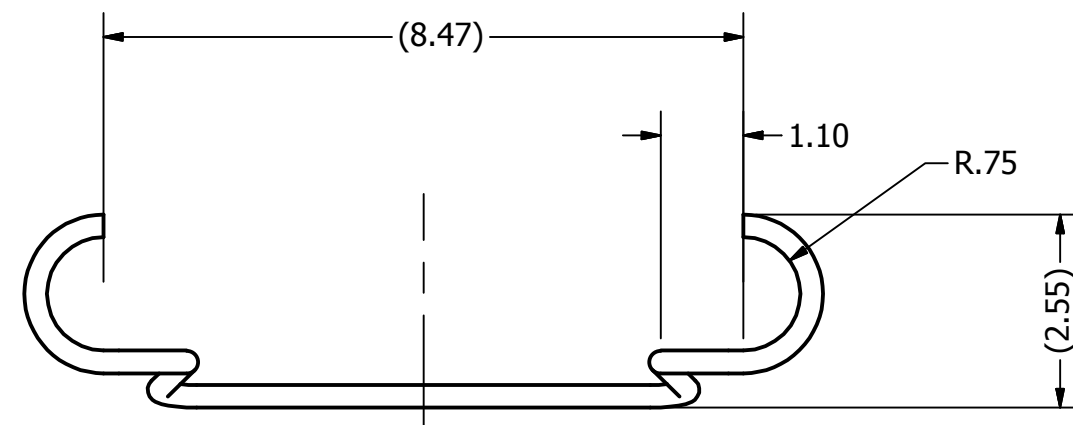
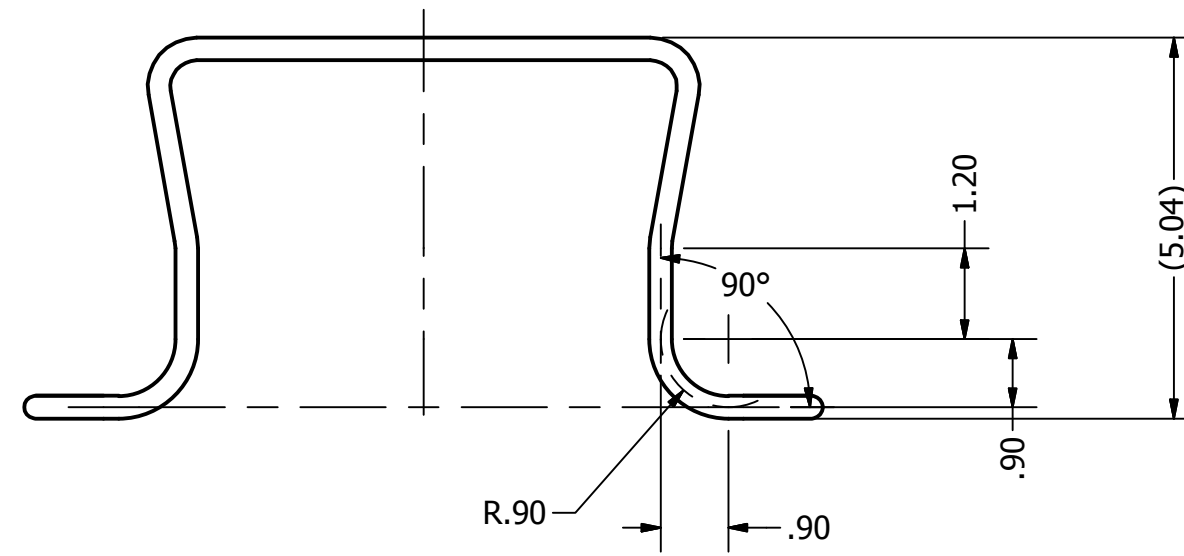

ENGINEER
Justine Haupt 12/21/2020

SKY'S EDGE
www.skysedge.us

(631) 965-3409
justine@skysedge.us

ALL UNITS IN MM
DECIMAL TOLERANCES:

X = ±.50
X.X = ±.30
X.XX = ±.16
X.XXX = ±.08

ALL SURFACES
Ra μm .8
UNLESS OTHERWISE NOTED

GOVERNOR SPRING

SIZE	PROJECT	DWG NO	REV
C		4GRCPGS1	0