

NOTES:

- 1. FOR REFERENCE ONLY
- 2. ASSOCIATED CAD FILE: GOVERNORGEAR.STP

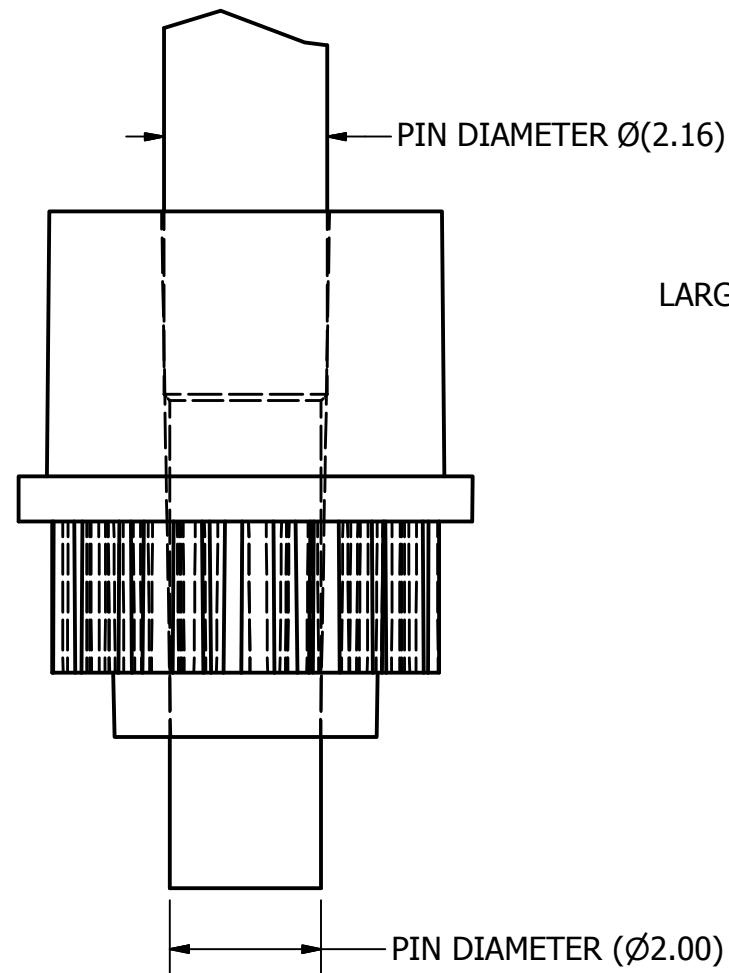

LARGE SIDE OF HOLE FACES UP

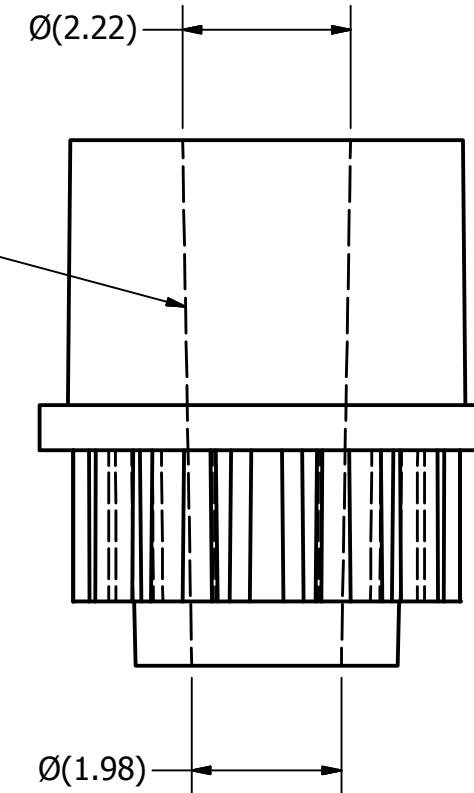

ENGINEER  
Justine Haupt 6/15/2021

ALL UNITS IN MM  
DECIMAL TOLERANCES:

X =  $\pm .50$   
X.X =  $\pm .30$   
X.XX =  $\pm .16$   
X.XXX =  $\pm .08$

ALL SURFACES  
Ra  $\mu\text{m}$  .8 ✓  
UNLESS OTHERWISE NOTED

SKY'S EDGE  
www.skysedge.us

(631) 965-3409  
justine@skysedge.com

GOVERNOR GEAR HOLE DETAIL

SIZE	PROJECT	DWG NO	REV
B		GovernorDetail	0